



## 产品型号：OEM-Z216/EasyPump



## 流量范围

泵头型号	软管	内径×壁厚(mm)	毫升/转	流量范围(mL/min) (0.1-450rpm)	软管承压(Mpa)		重量(kg)
					间断	连续	
单通道 EasyPump I/III	13#	0.8×1.6	0.053	0.0053~23.85	0.27	0.17	0.6
	14#	1.6×1.6	0.27	0.027~121.5			
	19#	2.4×1.6	0.55	0.055~247.5			
	16#	3.1×1.6	0.933	0.093~419.85	0.24	0.14	
	25#	4.8×1.6	1.967	0.197~885.15			
	17#	6.4×1.6	3.333	0.333~149.85			
	18#	7.9×1.6	4.3	0.430~1935			
单通道 EasyPump II/ IV	15#	4.8×2.4	1.8	0.180~810	0.27	0.17	
	24#	6.4×2.4	2.733	0.273~1229.85			
	35#	7.9×2.4	3.833	0.383~1724.85	0.24	0.14	
	36#	9.6×2.4	5.167	0.517~2325.15			
双通道 EasyPump V/VI	13#	0.8×1.6	0.053	0.0053~23.85	0.27	0.17	
	14#	1.6×1.6	0.27	0.027~121.5			
	19#	2.4×1.6	0.55	0.055~247.5			
	16#	3.1×1.6	0.933	0.093~419.85	0.24	0.14	
	25#	4.8×1.6	1.967	0.197~885.15			



### 技术参数

产品型号	OEM-Z216/EasyPump
电机类型	直流减速电机
工作电源	DC24V
电机转速	450rpm
转速误差	≤±10%
工作环境	0-40°C, 80%RH

### 尺寸图 (单位:mm)

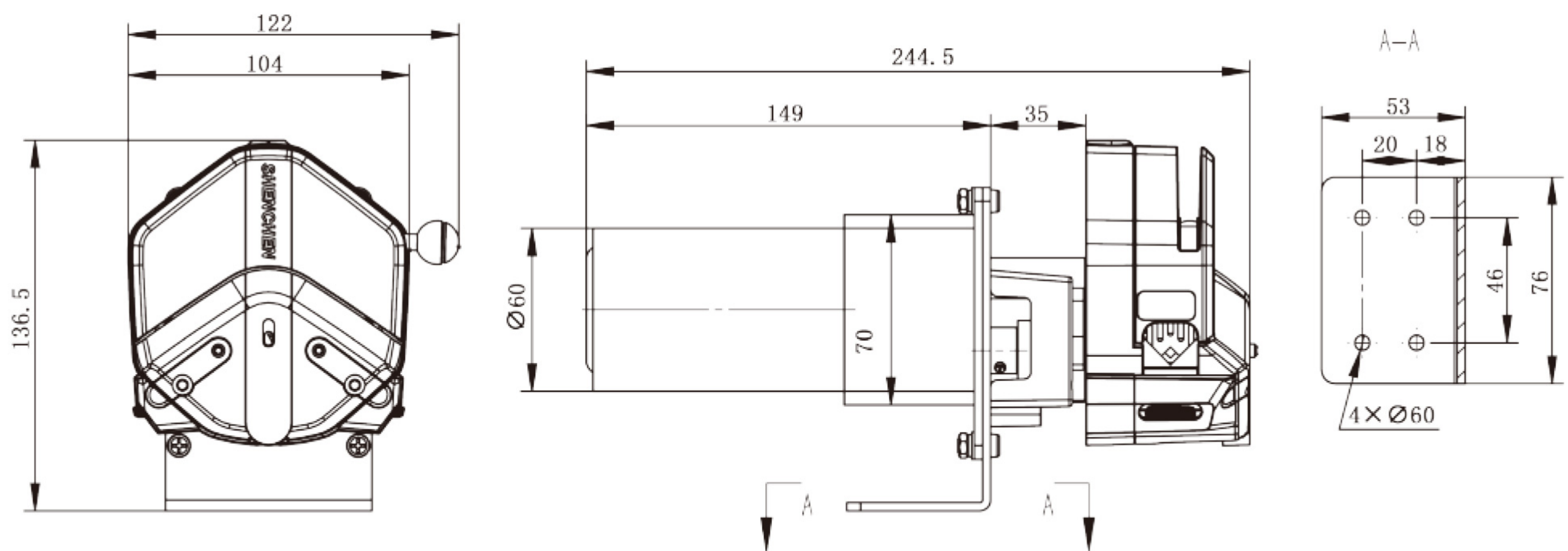

### 软管安装尺寸



1. 逆时针扳动扳杆180°，打开压块。



2. 搓轮调整。



3. 将软管自然放入上压块和滚轮之间。

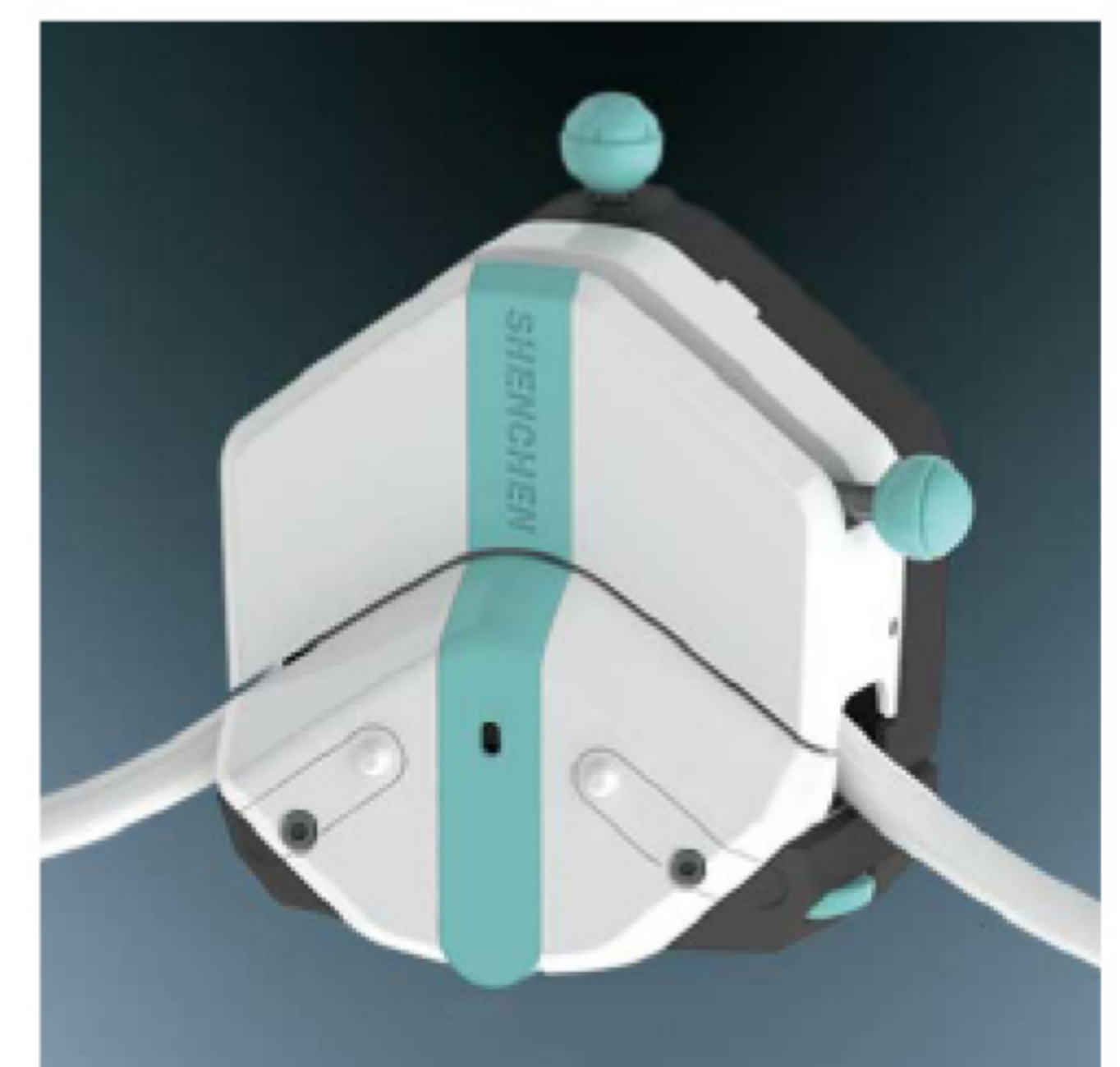

4. 顺时针扳动扳杆180°，使压块下压到位，压紧软管。